

ROYAL OIL CO.

SPECIALTY LUBRICANTS

POWER-TRANS FD

Additive Boosted TO-4 Fluid

Surpasses TO-4/C-4 Specs

Industry High Anti-Wear

Excellent Thermal Stability

Tackifiers for Film Strength

No-Foam/Preserves Seals

Reduces Operating Temps

Exceptional Service Life

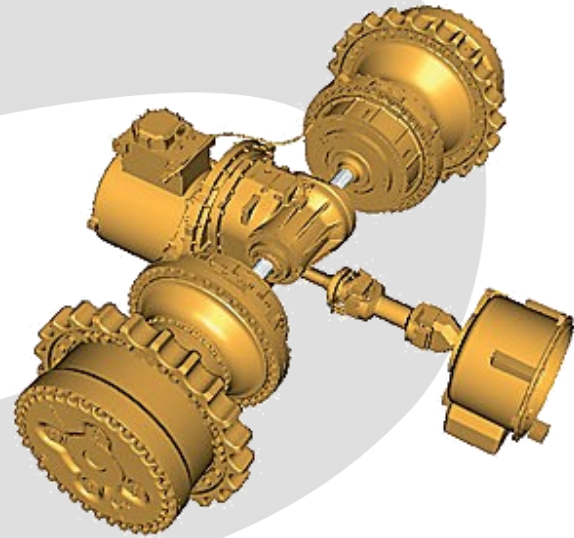

POWER-TRANS FD is without question one of the most impressive products in our line. Designed specifically for a current customer, the boosted additive product exceeds standard specifications and expectations for CAT TO-4 and Allison C-4 applications.

With a powerful non-foaming package and adhesive film strength improvers, POWER-TRANS FD protects final drive and planetary gear applications better than any other product in the industry. Reducing heat, wear, seal damage and failures, this is the product to utilize for track equipment, heavy transmission and a variety of other challenging gear applications.

“Our willingness to be persistent and innovative brought us POWER-TRANS FD and reaffirmed the importance of setting our own standards.”

POWER-TRANS FD

Product Specifications

Formulated to Meet Allison C-4, Caterpillar TO-4 and API CF and CF-2 Specifications

	TYPICAL TESTS		
SAE Grade	SAE 10	SAE 30	SAE 50
API Gravity	29.0	27.0	26.1
Specific Gravity	0.88	0.89	0.90
Weight per Gal., Lbs.	7.28	7.40	7.47
Flash Point, °F. (°C.)	420 (215)	460 (238)	460 (238)
Fire Point, °F. (°C.)	455 (235)	500+ (260+)	500+ (260+)
Pour Point, °F. (°C.)	-35 (-36)	-22 (-30)	-0.5 (-18)
Viscosity, SUS at 100°F.	207	550	1080
Viscosity, SUS at 210°F.	47.6	66.1	91.8
Viscosity, 40°C. cSt	43.86	118.77	226
Viscosity, 100°C. cSt	6.48	11.9	18.21
Viscosity Index	105	105	105
Copper Strip Corrosion, (2 Hrs. @ 100°C.)	1A	1A	1A
Fluid Compatibility	Pass	Pass	Pass
Homogeneity	Pass	Pass	Pass
Foam Test 0/0 0/0 0/0			
TO-4 Fluoroelastomer Seal Test	Pass	Pass	Pass
FZG Gear Wear	Pass	Pass	Pass
Vickers Pump Test	Pass	NR*	NR*
C-4 THOT	Pass	Pass	Pass
VC 70 Friction Test	Pass	Pass	Pass
Brookfield Viscosity, cPs	86,000 @ -35° C. 134,000 @ -25°C. 135,000 @ -15°C.		
High Temperature High Shear at 1500C.	2.22	3.42	5.0
Calcium, Wt. %	0.31	0.31	0.31
Zinc, Wt. %	0.12	0.12	0.12
Phosphorus, Wt. %	0.11	0.11	0.11
Color	Green	Green	Green
Allison C-4 Approval	C4-24292896	C4-24302896	—

Sharing lubricant knowledge and delivering the highest quality products, two things we promise our customers. The difference will change how you view, purchase and utilize greases and oils from here forward.

Family owned and operated since 1926.



842 N. Main St.
Fort Worth, TX 76164
(800) 332-1926
sales@royaloilus.com
www.royaloilus.com

